

VACUUM CONVEYOR

EXAMPLE OF MATERIALS THAT HAVE BEEN TESTED BY SOLID

Acetylsalicylic acid
 Aerosil
 Aluminium oxide
 Aluminium stearate
 Baron acid
 Brewer's yeast
 Calcium chloride
 Calcium stearate
 Calcium nitrate
 Carbon, active
 Carrots, dried
 Caustic soda
 Cellulose powder
 Citric acid
 Cocoa beans
 Cocoa powder

Coffee
 Coffee beans
 Colour powder
 Detergents
 Dextrose
 Dicalite
 Fat substance powder
 Filter material
 Fish food
 Fish food pellets
 Gelatin powder
 Graphite powder



PVC powder
 Resin powder
 Rice
 Rubber granules
 Rye flour
 Salt
 Sand
 Senegal potash
 Silica
 Soap flakes
 Sodium perborate
 Sodium sulphate
 Soya flour
 Spices
 Sprinkles
 Starch
 Sugar caster
 Sugar, granulated
 Talc
 Tea
 Tensides
 Titanium dioxide

Gun powder
 Gypsum
 Iron oxide
 Kieselguhr
 Lactose
 Lime
 Magnesium oxide
 Maize flour
 Maize, grains
 Maize starch
 Malt
 Manganese dioxide
 Melt glue granules
 Micromaya
 Milk powder
 Muesli
 Mustard seeds
 Nib sugar
 Nickel powder
 Zinc white
 Nuts
 Peas

What it's Vacuum Conveyor?

Vacuum is used with great advantage in conveying dry powder products through dedicated pipe systems solid vacuum conveying systems are built of high quality material.

When producing food, pharmaceuticals and chemical products there are demands on the highest possible degree of safety as to hygiene and operation. SOLID vacuum conveyors have been developed as an answer to the severe requirements of operational safety and hygiene in the food, pharmaceutical and chemical industries.



Main Advantages

- Automatic filter cleaning
- Low noise level
- Quick deliver (stock)
- System
- Minimal maintenance
- Low energy consumption
- Simple to install
- Polished steel
- Compact size
- Dustless conveying
- Made of acid-proof
- Easy to maintenance
- Light weight
- Easy to installation
- Easy to clean

VACUUM CONVEYOR

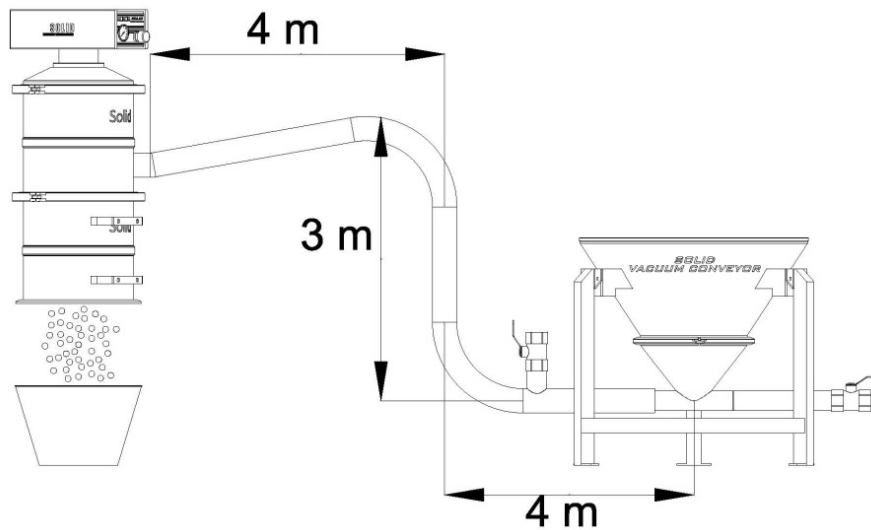

HOW TO SELECT A STANDARD CONVEYOR

EXAMPLE ...

The Sugar Company needs to convey 0.8 tons of granulate Sugar per hour up to a mixer where the sugar is mixed with cacao powder. The mixer is located 11 meters from the Feed station

The power requirement (P_r) of the applications is the same as the customer's capacity requirement. Hear the P_r figure, which is the product of capacity and conveying distance, is calculated.

- ▶ Material : granulated sugar
- ▶ Capacity : $C = 1.2$ ton/hour
- ▶ Vertical conveying distance : $L_v = 3$ meters
- ▶ Horizontal conveying distance : $L = 4 + 4 = 8$ meters
- ▶ Total conveying distance : $L = L_v + L = 3 + 8 = 11$ meters
- ▶ Characteristics of granulated coffee
 - Bulk density $B = 0.8$ ton/m³
 - Particle size $P = 0.2$ mm
 - The coffee is a free flowing product

$$Pr = CXL = 0.8 \times 11 = 8.8$$

▶ Pr : Power requirement

SOLID vacuum conveyor "SOLID 200" will be the best choice when the $Pr = 10 \sim 20$ in this Example,

To check ;

- ▶ Bulk density, $B = 0.8$ ton/m³ ($0.5 < B < 18$) OK!
- ▶ Total conveying distance, $L = 11$ m, ($4 < L < 30$) OK!
- ▶ Particle size, $P = 0.2$ mm ($P < 5$ mm) OK!

Note ; The above is only a suggestion in order to facilitate the choice of

There are many applications in the market, some with higher and some with lower values than the values mentioned here.

Therefore, please contact our VTEC for more detailed product information.

VACUUM CONVEYOR

"Type SOLID 100 ..."

Supply air pressure	: 4 ~ 6 bar, (Max 7 bar) (58 ~ 87 psi, Max. 101.5 psi)
Air consumption	: 300 ~ 420 NI/m (10.59 ~ 14.83 scfm)
Power Requirement	: 3 -6
Noise level	: 68 ~ 76 dBA
Steel Material	: SUS 304 / SUS 316L
Sealing Material	: Silicone
Filter Material	: • TFE coated antistatic needle felt of polyester / carbon fibers • Washable 2 to 4 times in 40°C • Food quality
Working temp.	: - 20°C ~ + 80°C



Contact Us...

Ordering Information

SOLID 100 L - EC - 4
 ↓ ↓ ↓ ↓
 ① ② ③ ④

1. Vacuum pump

100 - Vacuum Pump with Free flow silencer
 - (Standard)

2. Filtration Area

No mark - Standard (14 dm²)

L - Extra large (26 dm²)

3. Control Unit

EC - Electric control.
 - Adjustable running time / discharge time.
 Available level

4. Bag filter (Blowing)

No mark - Standard (11 dm²)

0.5m - Extra large

Specification

Model	Max.Conveying Capacity (ton)	Capacity ton/h at different conveying distance				Rec. Material Pipe dimension	Rec. Material Volume	Weight (kg)
		5m	10m	20m	30m			
SOLID 100	0.9	0.9	0.45	0.22	-	22 / 32	1	15

Contact Us...

VACUUM CONVEYOR

"Type SOLID 200 ..."

Supply air pressure	:	4 ~ 6 bar, (Max 7 bar) (58 ~ 87 psi, Max. 101.5 psi)
Air consumption	:	600 ~ 780 NI/m (2118 ~ 27.54 scfm)
Power Requirement	:	5 - 10
Noise level	:	68 ~ 76 dBA
Steel Material	:	SUS 304 / SUS 316L
Sealing Material	:	Silicone
Filter Material	:	<ul style="list-style-type: none"> • TFE coated antistatic needle felt of polyester / carbon fibers • Washable 2 to 4 times in 40°C • Food quality
Working temp.	:	- 20°C ~ + 80°C



Contact Us...

Ordering Information

SOLID 200 L - EC - 4
 ↓ ↓ ↓ ↓
 ① ② ③ ④

1. Vacuum pump

200 - Vacuum Pump with Free flow silencer (Standard)

2. Filtration Area

No mark - Standard (14 dm²)
 L - Extra large (26 dm²)

3. Control Unit

EC - Electric control.
 - Adjustable running time / discharge time.
 Available level

4. Bag filter (Blowing)

No mark - Standard (11 dm²)
 0.5m - Extra large

Specification

Model	Max.Conveying Capacity (ton)	Capacity ton/h at different conveying distance				Rec. Material Pipe dimension	Rec. Material Volume	Weight (kg)
		5m	10m	20m	30m			
SOLID 200	1.5	1.5	0.8	0.4	0.2	32 / 40 / 50	4	22

VACUUM CONVEYOR

Dimension Information

Series SOLID 100... / 100L...

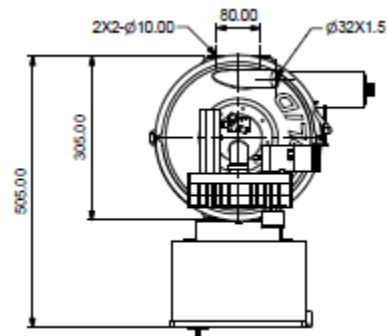
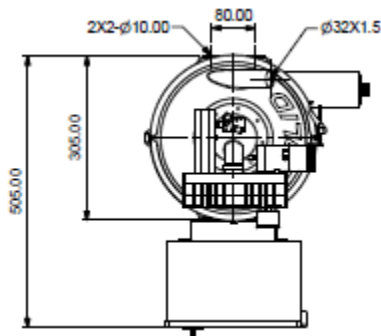
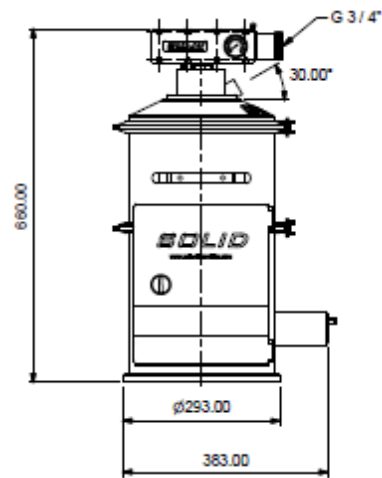
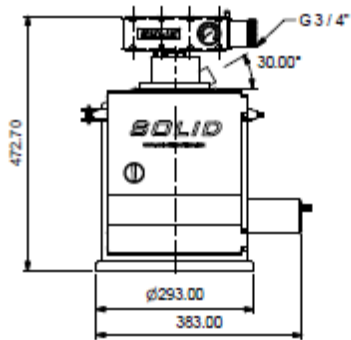

SOLID 100

SOLID 100L

Dimension Information

Series SOLID 200... / 200L...

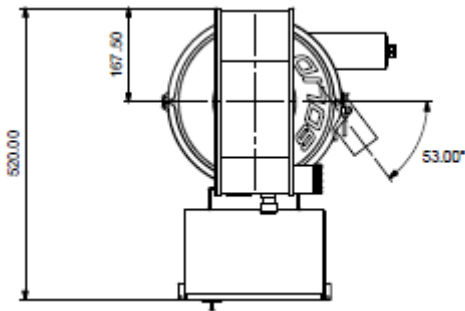
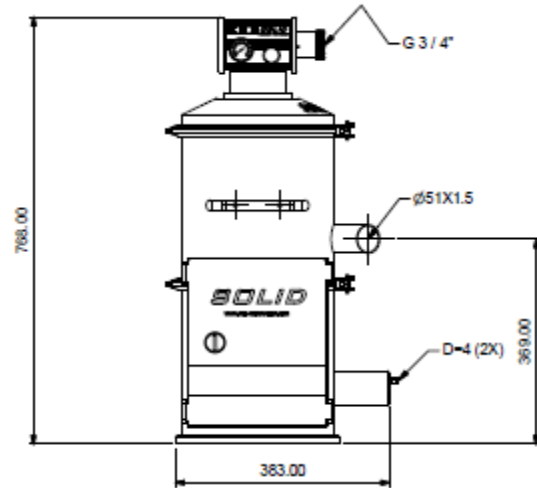
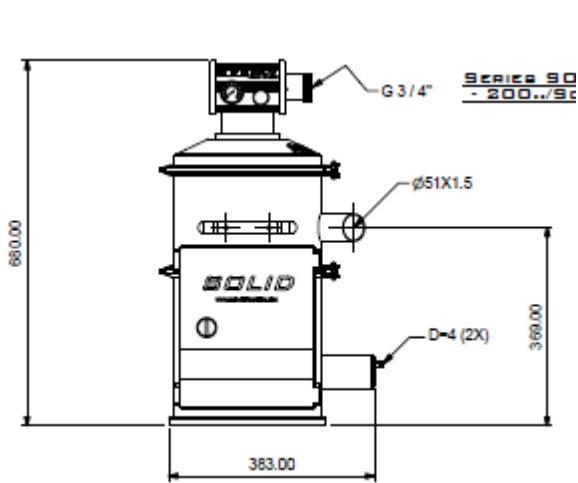

SOLID 200

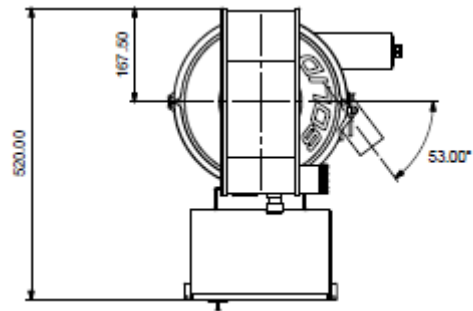

SOLID 200L

Application

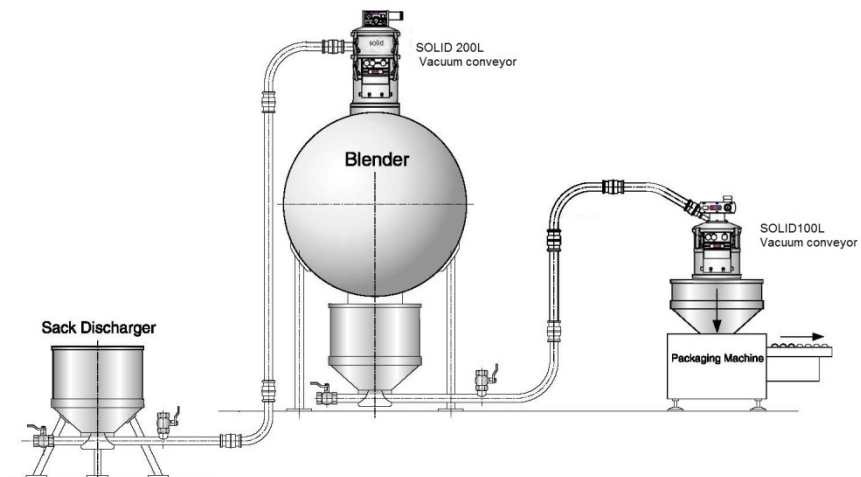

Contact Us...

Application



Tablet machine



Tank mixer



VACUUM CONVEYOR



Cube mixer



Note...

Note...